

# TOOLS

Bulletin# 021616

DATE: 02-23-2016

© Copyright 2016

## 210.1224CB SOCKET CAGING BOLT

**REPLACES:**

49000

**DESCRIPTION:**

3/4" 6Pt Extra Deep Caging Bolt Socket, 1/2" Drive



## 182.BRDS-6 RACE DRIVER SET

**REPLACES:**

61900

**DESCRIPTION:**

Bearing Race Driver Set Includes:

- 182.DP212011,
- 182.DP218210,
- 182.DP3720,
- 182.DP518410,
- 182.DP552A,
- 182.DP572,
- 181.DP-HANDLE



## 181.1002 WHEEL SEAL PULLER

**REPLACES:**

SRT1

**DESCRIPTION:**

Heavy Duty Puller Provides Leverage To Pull Stubborn Wheel Seals, 30" Length



## 579.1053 RACE INSTALLER

**REPLACES:**

7180, E6040

**DESCRIPTION:**

Universal Bearing Race Installer Adjusts To Fit Races From 3-5/8" To 6-1/2" Diameters



## 181.SDS-6 SEAL DRIVER SET

**DESCRIPTION:**

Oil Seal Driver Set

Includes:

- 181.DP001, 181.DP003,
- 181.DP023, 181.DP025,
- 181.DP036, 181.DP065,
- 181.DP-HANDLE



## 579.1050 ANCHOR PIN PRESS

**REPLACES:**

11-1887, 7248, E2654, M-2586

**DESCRIPTION:**

Install/ Remove Brake Anchor Pins



### AXLE NUT SOCKETS - 6PT (3/4" DRIVE)



210.1916

Automann #	Description
210.1901	2-3/32" 6Pt Wrench
210.1900	2-1/8" 6Pt Wrench; 1/2" Drive
210.1920	2-1/4" 6Pt Wrench
210.1902	2-3/8" 6Pt Wrench
210.1936	2-3/8" 6Pt Rounded
210.1921	2-1/2" 6Pt Wrench
210.1904	2-9/16" 6Pt Wrench
210.1928	2-9/16" 6Pt Rounded
210.1922	2-5/8" 6Pt Wrench
210.1923	2-3/4" 6Pt Wrench
210.1932	2-7/8" 6Pt Wrench

Automann #	Description
210.1906	3" 6Pt Wrench
210.1934	3-1/8" 6Pt Wrench
210.1908	3-1/4" 6Pt Wrench
210.1910	3-1/2" 6Pt Wrench
210.1926	3-3/4" 6Pt Wrench
210.1912	3-7/8" 6Pt Wrench
210.1914	4" 6Pt Wrench
210.1915	4-1/8" 6Pt Wrench
210.1916	4-3/8" 6Pt Wrench
210.1918	4-7/8" 6Pt Wrench
210.1939	5-1/4" 6Pt Wrench

### AXLE NUT SOCKETS - 8PT (3/4" DRIVE)



210.1937

Automann #	Description
210.1903	2-3/8" 8Pt Wrench
210.1905	2-9/16" 8Pt Wrench
210.1937	2-3/4" 8Pt Wrench
210.1933	2-7/8" 8Pt Wrench
210.1907	3" 8Pt Wrench
210.1935	3-1/8" 8Pt Wrench
210.1909	3-1/4" 8Pt Wrench
210.1924	3-3/8" 8Pt Wrench
210.1911	3-1/2" 8Pt Wrench

Automann #	Description
210.1925	3-3/4" 8Pt Wrench
210.1927	3-13/16" 8Pt Wrench
210.1913	3-7/8" 8Pt Wrench
210.1940	4-1/8" 8Pt Wrench
210.1917	4-3/8" 8Pt Wrench
210.1938	4-1/2" 8Pt Wrench
210.1941	4-13/16" 8Pt Wrench
210.1919	4-7/8" 8Pt Wrench

### 210.1942 DOUBLE ENDED SOCKET

**DESCRIPTION:**  
3-7/8" and 3-1/4" Ends

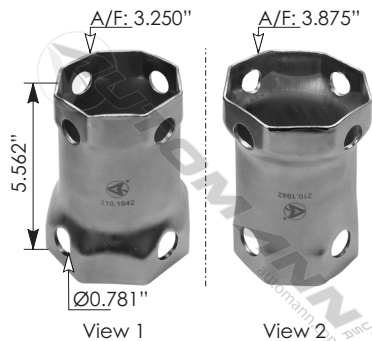

### 579.1051 THREAD CHASER

### THREAD CHASER

**REPLACES:**

11-1880, 7402,  
E2644, L1942,  
M-1942

**DESCRIPTION:**

Universal Thread Chaser  
For Standard Outside  
Threads;  
6 Dies Includes Sizes For  
4, 5, 6, 7, 7-1/2, 8, 9, 10,  
11, 11-1/2, 12, 14, 16, 18,  
20, And 24 TPI



### 579.1055

### RIM PROTECTOR

**REPLACES:**

19812, 30605

**DESCRIPTION:**

Used To Protect Wheel While Removing Lug Nuts

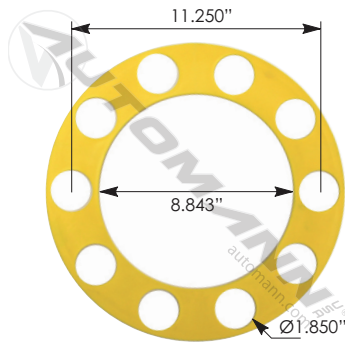

### 579.1076

### WRENCH

**REPLACES:**

7578

**DESCRIPTION:**

7/16" Ratcheting Wrench, For Crewson, Gunite, Haldex Type Automatic Slack Adjusters



### 579.1056

### BRAKE SPRING TOOL

**REPLACES:**

5081, M-3990

**DESCRIPTION:**

Provides Leverage To Install Brake Springs On S-Cam Brakes



### 579.1077

### WRENCH

**REPLACES:**

8569

**DESCRIPTION:**

9/16" Ratcheting Wrench, For Bendix Type Slack Adjusters



### 579.1060K

### PULLER KIT

**REPLACES:**

5054

**DESCRIPTION:**

Slack Adjuster Puller Kit, Consists Of 579.1057, 579.1058, 579.1059



### 579.1078

### CHECK TOOL

**REPLACES:**

11-1841, 5052

**DESCRIPTION:**

Slack Adjuster Check Tool



### 579.1075

### ADJUSTER TOOL KIT

**REPLACES:**

4651

**DESCRIPTION:**

Meritor Type Automatic Slack Adjusters, Includes Release Tool And Wrench

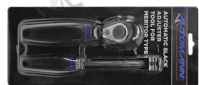

### 210.1968

### NUT WRENCH

**REPLACES:**

11-1968, 30609, E5855, M-155

**DESCRIPTION:**

Hold 1-1/2" Outer Wheel Nut While Inner Nut is Loosened

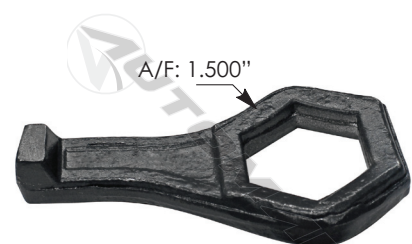

Thickness: 0.562"

## 210.2005K

### 1" SOCKET SET

**CONTAINS:**

5 Sockets (33MM)  
to (1-1/2")

**APPLICATION:**

5 pc 1" Drive Deep Impact  
Socket Set for Wheel Service



Socket	Size
210.2033D	33MM
210.2135D	35MM, 17MM
210.2138D	38MM
210.2141D	41MM, 21MM square
210.2112D	1-1/2", 13/16" square

## 210.3405K

### 3/4" SOCKET SET

**CONTAINS:**

6pt Sockets (1-1/16"), (1-1/2"),  
(33MM), Square Socket (13/16")

**APPLICATION:**

5 pc 3/4" Drive Wheel Service  
Impact Socket Set



Socket	Size
210.3434D	1-1/16"
210.3440D	1-1/4"
210.3448D	1-1/2"
210.3433MD	33MM
210.3426S	13/16" square

## 210.2004TSK

### TORQUE SOCKET KIT

**REPLACES:**

44000

**DESCRIPTION:**

Torque Socket Kit, 4 pc,  
1" Drive, Includes:  
210.2033TS 210.2114TS  
210.2112TS 210.21316TS



## 579.1010

### TIRE DEMOUNTING TOOL

**REPLACES:**

35440

**DESCRIPTION:**

Easily Demount  
Truck Tires With  
Only This Tool



## 579.1052

### ADJUSTING WRENCH

**REPLACES:**

11-1884, 7028,  
E6041

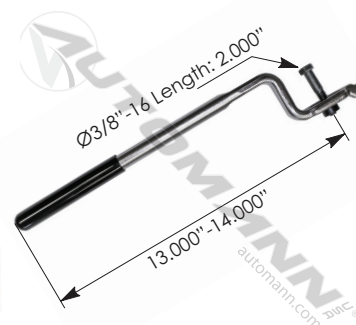

## 579.1063

### U-JOINT PULLER

**REPLACES:**

5190

**DESCRIPTION:**

Universal,  
Spicer Series 1610, 1710,  
1760, 1810, 1880, SPL  
Series,  
Meritor RPL Series U-Joints

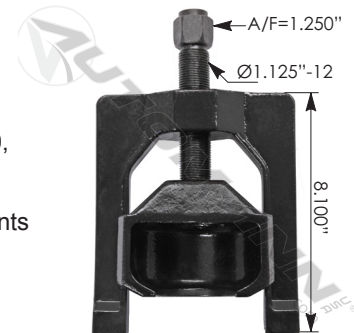

## 579.1064

### U-JOINT PULLER

**REPLACES:**

7490, E6039

**DESCRIPTION:**

U-Joints With 2 Bolt Bearing  
Plate

